

**FRONT VIEW  
ROUND PIPE CULVERT**

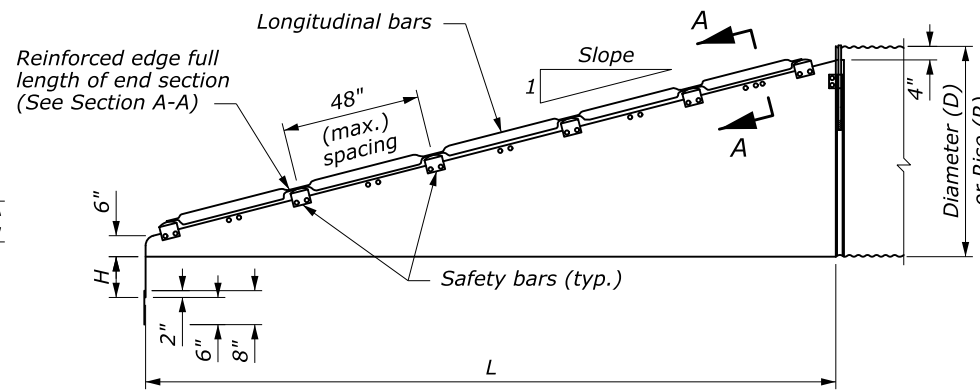

**ELEVATION  
CROSS DRAINAGE END SECTION**

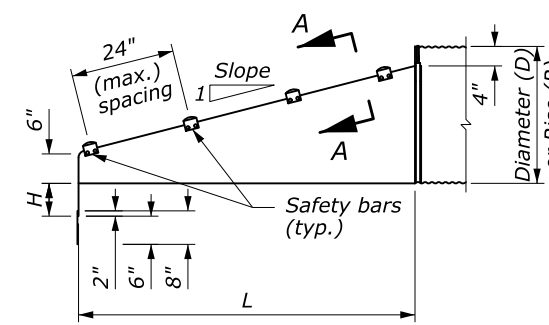

**ELEVATION  
PARALLEL DRAINAGE END SECTION**

**NOTE:**

1. Use end sections on 1V:4H to 1V:6H slopes only. Use toe plate extension where shown on the plans.
2. Fabricate safety and longitudinal bars from steel pipe conforming to ASTM A53 schedule 40 specifications. Galvanize bars hot dipped after fabrication.
3. A longitudinal bar is required for cross drainage end sections when the span is greater than 30". Use additional longitudinal bars if spacing exceeds 30" on larger end sections.
4. Safety and longitudinal bars are not required on 30" and smaller cross drainage end sections.
5. Safety bars are not required on 18" and smaller parallel drainage end sections.
6. 18" diameter sleeves have a thickness of 0.079", all others are 0.109".

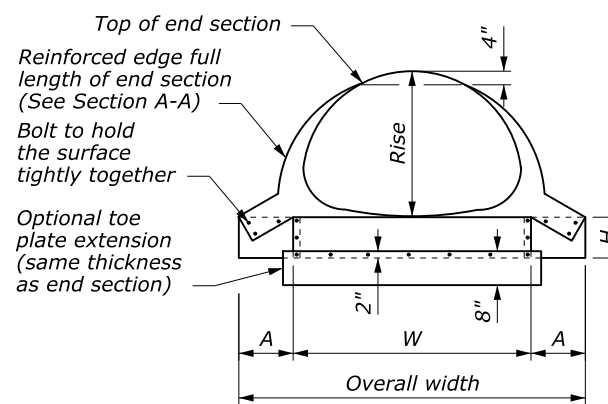

**FRONT VIEW  
PIPE ARCH CULVERT**

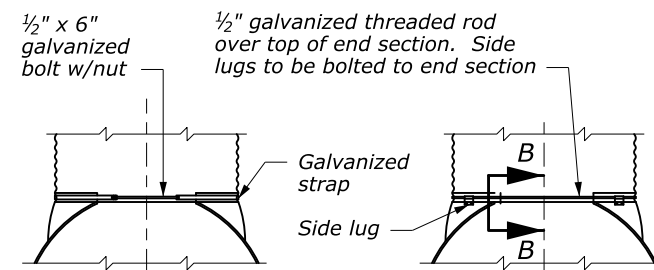

FOR METAL ROUND PIPES 15" THRU 24"

TYPE #1

FOR METAL ROUND PIPES 30" AND LARGER. FOR PIPE ARCHES 21" X 15" AND LARGER

TYPE #2

**CONNECTOR DETAILS**

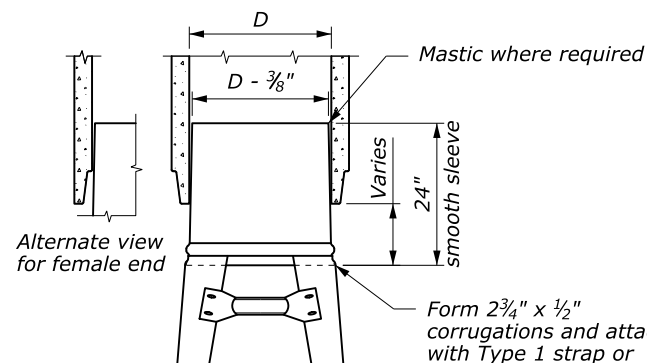

FOR ALL SIZES OF CONCRETE ROUND OR PIPE ARCHES

TYPE #3

METAL END SECTIONS FOR ROUND PIPE CULVERT								
PIPE SIZE Ø INCHES	METAL THICK (MIN.) INCH/GAGE	DIMENSIONS IN INCHES						
		A	H	W	OVERALL WIDTH	L		
						Slope=4	Slope=6	
18	0.064/16	8	6	24	40	32	47	
24	0.064/16	8	6	30	46	55	83	
30	0.109/12	12	9	36	60	79	118	
36	0.109/12	12	9	42	66	102	154	
42	0.109/12	16	12	48	80	126	189	
48	0.109/12	16	12	54	86	150	224	
54	0.109/12	16	12	60	92	173	260	
60	0.109/12	16	12	66	98	197	295	

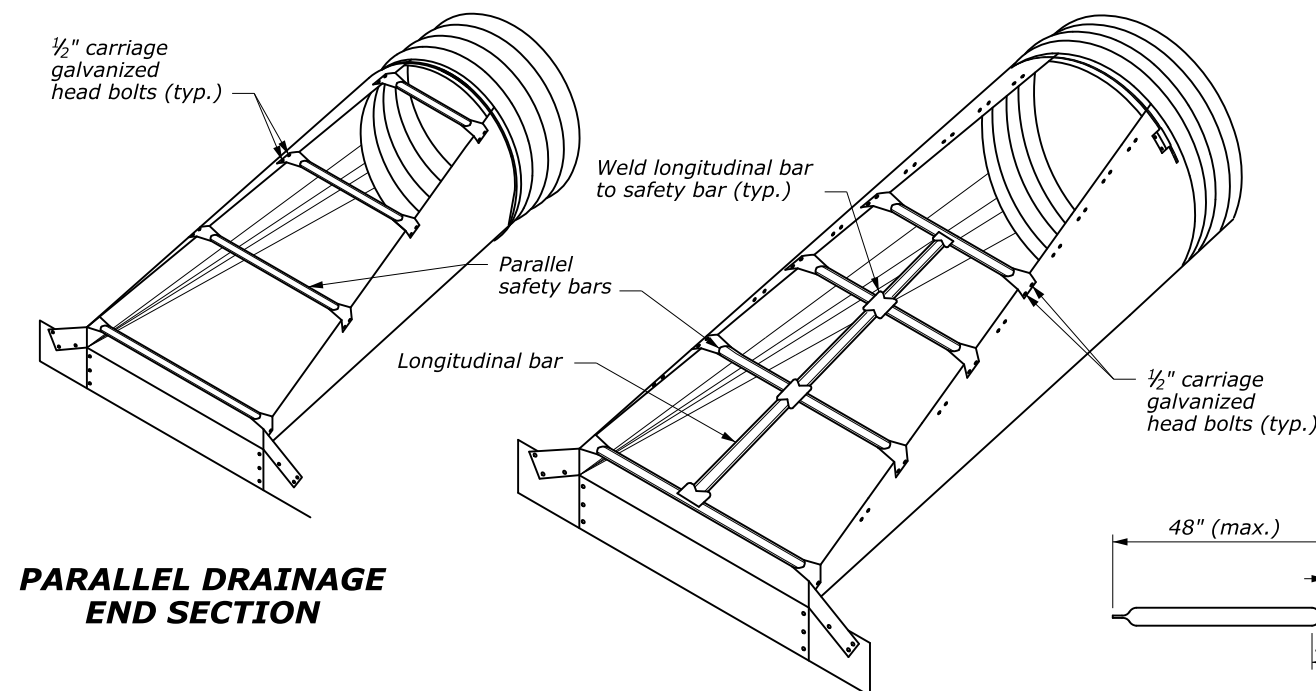

**PARALLEL DRAINAGE  
END SECTION**

**CROSS DRAINAGE END SECTION**

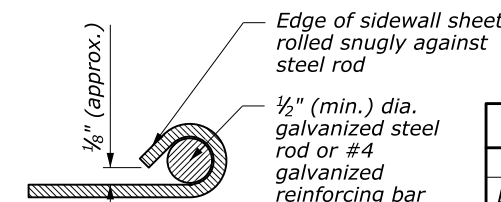

SECTION A-A

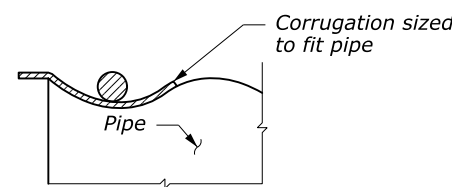

SECTION B-B

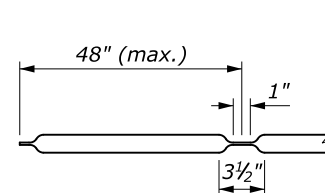

LONGITUDINAL DRAINAGE BAR

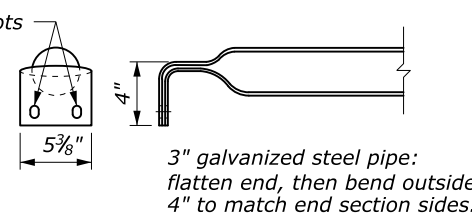

PARALLEL BARS

METAL END SECTIONS FOR PIPE ARCH CULVERT									
EQUIV. Ø	SPAN	RISE	METAL THICK (MIN.) INCH/GAGE	DIMENSIONS (INCHES)					
				A	H	W	OVERALL WIDTH	L	
								Slope=4	Slope=6
18	21	15	0.064/16	8	6	27	43	20	30
24	28	20	0.064/16	8	6	33	49	40	60
30	35	24	0.109/12	12	9	40	64	55	83
36	41	29	0.109/12	12	9	47	71	75	112
42	48	32	0.109/12	16	12	54	86	90	136
48	56	37	0.109/12	16	12	62	94	110	165
54	63	42	0.109/12	16	12	69	101	130	195
60	70	46	0.109/12	16	12	76	107	146	218
72	82	56	0.109/12	16	12	88	120	185	278

**SAFETY BAR DETAILS**

NO SCALE

U.S. DEPARTMENT OF TRANSPORTATION  
FEDERAL HIGHWAY ADMINISTRATION  
FEDERAL LANDS HIGHWAY

U.S. CUSTOMARY STANDARD

**METAL END SECTIONS  
WITH SAFETY BARS**

STANDARD APPROVED FOR USE 6/2005  
REVISED:

STANDARD  
602-9